

# Model CM0900

## 1 Phase Automatic Transfer Switch Controller



McPherson Controls  
4501 NW 27 Ave  
Miami, FL 33142

Ph 305-634-1511 Fax 305-634-1461

## TABLE OF CONTENTS

Section	Page
SECTOIN 1 : INTRODUCTION	
1.1 Preliminary Comments and Safety Precautions.....	3
1.2 Background .....	3
1.3 Product Overview .....	3
1.4 Functions / Features.....	3
SECTOIN 2 : HARDWARE DESCRIPTION	
2.1 General.....	5
2.2 Auto / Test Pushbutton .....	5
2.3 Panel LEDs Outputs .....	5
2.4 Rear Access Area .....	5
2.5 Connector & Terminals Functions .....	5
SECTOIN 3 : OPERATOR PANEL	
3.1 General.....	8
3.2 Auto / Test Pushbutton .....	8
3.3 Panel LED Outputs.....	8
SECTOIN 4 : OPERATION	
4.1 General.....	8
4.2 Auto Mode .....	8
4.3 Test Mode.....	9
4.4 Programming.....	9
SECTOIN 5 : INSTALLATION INSTRUCTIONS	
5.1 General.....	9
5.2 Panel Cut-Out .....	9
5.3 Unit Dimensions .....	10
SECTOIN 6 : TYPICAL WIRING	
6.1 General.....	10
6.2 Typical connecting wire diagram .....	11
6.3 Connecting wire diagram When the transfer current over 6 Amps .....	13

## SECTION 1 : INTRODUCTION

### 1.1 Preliminary Comments and Safety Precautions

This technical document is intended to cover most aspects associated with the installation, application, operation and maintenance of the CM0900 Automatic Transfer Switch Controller. It is provided as a guide for authorized and qualified personnel application of the CM0900 Automatic Transfer Switch Controller.

### 1.2 Background

Transfer switches are used to protect critical electrical loads against loss of power. The load's normal power source is backed up by a standby (emergency) power source. A transfer switch is connected to both the normal and emergency sources and supplies the load with power from one of these two sources. In the event that power is lost from the normal source, the transfer switch transfers the load to the standby source. Once normal power is restored, the load was transferred back to the normal power source.

When using the CM0900 module in automatic transfer switch equipment, the switch's intelligence system initiates the transfer when normal power falls below or over a preset voltage. If the emergency source is a standby generator, the transfer switch initiates generator starting and transfers to the standby source when generator is available. When normal power is restored, the transfer switch automatically transfers back and initiates engine shutdown after a preset engine cooling down time delay.

An automatic transfer switch consists of three basic elements:

1. Main contacts to connect and disconnect the load to the source of power.
2. A transfer mechanism to affect the transfer of the main contacts from one source to another source.
3. Intelligence control unit to constantly monitor the condition of the power sources and thus provide the intelligence necessary for the switch and related circuit operation.

This manual deals with the third basic element of the automatic transfer switch, the required intelligence automatic controller. All the Automatic Transfer Switch functions were performed by a door mounted logic panel CM0900 control unit. The CM0900 logic panel brings intelligence, supervisory and adjustable capabilities to automatic transfer switch equipment.

### 1.3 Products Overview

The CM0900 Automatic Transfer Switch module is an intelligence, microprocessor based automatic transfer switch controller. It is a compact panel mounted device designed to replace traditional relay and solid state logic panels.

The CM0900 controller provides an unmatched degree of programmed flexibility to address the needs of motor drive switch or magnetic contactor system. It provides the necessary intelligence to insure that the switch operates properly through a series of timing functions. The CM0900 controller will :

- Monitor normal source over and under voltages.
- Permit system testing the transfer switch with load from front panel.
- Permit customer plant engine test without load by external exerciser timer.
- Provide the source status and fail alarm indications on the front panel.

### 1.4 Functions / Features

The primary function of CM0900 controller is to accurately monitor power sources and provide the necessary intelligence to operate a transfer switch in an appropriate and timely manner.

From installation to programming to usage, the CM0900 controller was designed with operational simplicity in mind. The CM0900 controller operates with system voltage from 160 VAC to 270 VAC at 50 or 60 Hz.

#### 1.4.1 Standard Features

The features can be simply adjusted by customer via 9 dip-switches, depending upon customer requirements.

**Feature 1 :Switch Type selected**

The CM0900 controller provides an unmatched degree of programmed flexibility to address the needs of motor drive switch or magnetic contactor system. ( refer to programming table )

**Feature 2 :Time Delay Normal to Emergency (TDNE)**

TDNE provides a time delay when transferring the Normal source to the Standby source. It ensures stability of the Standby source. ( refer to programming table )

Adjustable TDNE range : 2 、 10 、 20 and 30sec

**Feature 3 : Time Delay Engine Start (TDES)**

TDES delays the initiation of the engine start circuit in order to override momentary power outages or voltage fluctuations of the Normal source. The TDES timer shall start when the Normal source becomes unavailable. If the Normal source becomes available while timing, the TDES timer will reset. The CM0900 controller can perform the time delay engine start function without control power for 15 seconds. ( refer to programming table )

Adjustable TDES range : 2 、 5 、 10 and 15sec

**Feature 4 : Time Delay Emergency to Normal (TDEN)**

TDEN delays the transfer from the Standby source to the Normal Source to permit stabilization of the Normal Source before retransfer is made. Timing begins when the Normal Source becomes available. ( refer to programming table )

Adjustable TDEN range : 2 、 10 、 120 and 300sec

**Feature 5 : Time Delay Engine Cool-down (TDEC)**

TDEC permits the generator to continue to run unloaded after retransfer to the Normal Source has occurred. Timing begins when the transfer to normal has been completed. ( refer to programming table )

Adjustable TDEC range : 2 、 30 、 120 and 300sec

**Feature 6 : Under / Over voltage Sensing**

The controller monitors the voltage of the normal power source.

Build-in un-adjustable Over volt setting : 270VAC

Build-in Over volt reset setting : 265VAC



















Build-in un-adjustable Under volt setting : 180VAC

Build-in Under volt reset setting : 185VAC

**Feature 7 : External Plant Exerciser**

The CM0900 module accepted customer plant engine test without load on a preset period. There are 4 terminals on the rear of CM0900 module to accept external exerciser timer signal input (TB1-3 & TB1-4 ) and to provide AC220V power for external timer when the normal power is available.( TB1-1 & TB1-2)

Programming Table

1	Switch Type Selector		MCCB TYPE
			MC TYPE
2 3	TDEN Time Delay Emergency to Normal		2 Seconds
			10 Seconds
			2 Minutes
			5 Minutes
4 5	TDNE Time Delay Normal to Emergency		2 Seconds
			10 Seconds
			20 Seconds
			30 Seconds
6 7	TDEC Time Delay Engine Cool-down		2 Seconds
			30 Seconds
			2 Minutes
			5 Minutes
8 9	TDES Time Delay Engine Start		2 Seconds
			5 Seconds
			10 Seconds
			15 Seconds

## SECTION 2 : HARDWARE DESCRIPTION

### 2.1 General

The purpose of this section is to familiarize the reader with CM0900 hardware, its nomenclature, and to list the unit specifications. The information presented is divided into the following parts:

- **Auto/Test Pushbutton**
- **Panel LEDs Outputs**
- **Rear Access Area**
- **Connector & Terminals**

### 2.2 Auto/Test Pushbutton

The front operator panel supports a long-life Auto/Test pushbutton. Pushbuttons accomplish their function when pressed and released. Refer to Paragraph 3.3 for information concerning the function. (Refer to Figure 1)

### 2.3 Panel LEDs Outputs

Eight individual LEDs are lit when performing or indicating a specific function. For detailed information on individual LEDs refer to Paragraph 3.3. (Refer to Figure 1)

### 2.4 Rear Access Area

The rear access area of the CM0900 controller is normally accessible from the rear of panel. A wiring connector and terminals are made at the rear of the chassis. For detailed information of connecting wire diagram refer to Paragraph 6.

The CM0900 circuit board build-in 4 high voltage fuses for normal and standby input protected (Refer to rear layout Figure 2)

**Fuse Table**

PIN NO.	NOTES
Fuse1	Normal source protected fuse 6.3A
Fuse2	Normal source protected fuse 6.3A
Fuse3	Standby source protected fuse 6.3A
Fuse4	Standby source protected fuse 6.3A

### 2.5 Connector & Terminals Functions

The following describes the connections to the connector and terminals on the rear of CM0900 module. (Refer to rear layout Figure 2)

#### Connector 12 way

PIN NO.	NOTES
CN1-1	Normal source 220V input
CN1-2	Normal source 220V input
CN1-3	Null
CN1-4	Connect to Standby signal output
CN1-5	Normal connected signal input
CN1-6	Connect to Normal signal output
CN1-7	Connect to Normal signal output
CN1-8	Standby connected signal input
CN1-9	Connect to Standby signal output
CN1-10	Null
CN1-11	Standby source 220V input
CN1-12	Standby source 220V input

#### Terminals 6 way

PIN NO.	NOTES
TB1-1	External exerciser timer power 220V output
TB1-2	External exerciser timer power 220V output
TB1-3	External plant test signal input
TB1-4	External plant test signal input
TB1-5	Engine remote start signal output
TB1-6	Engine remote start signal output

## Front Panel

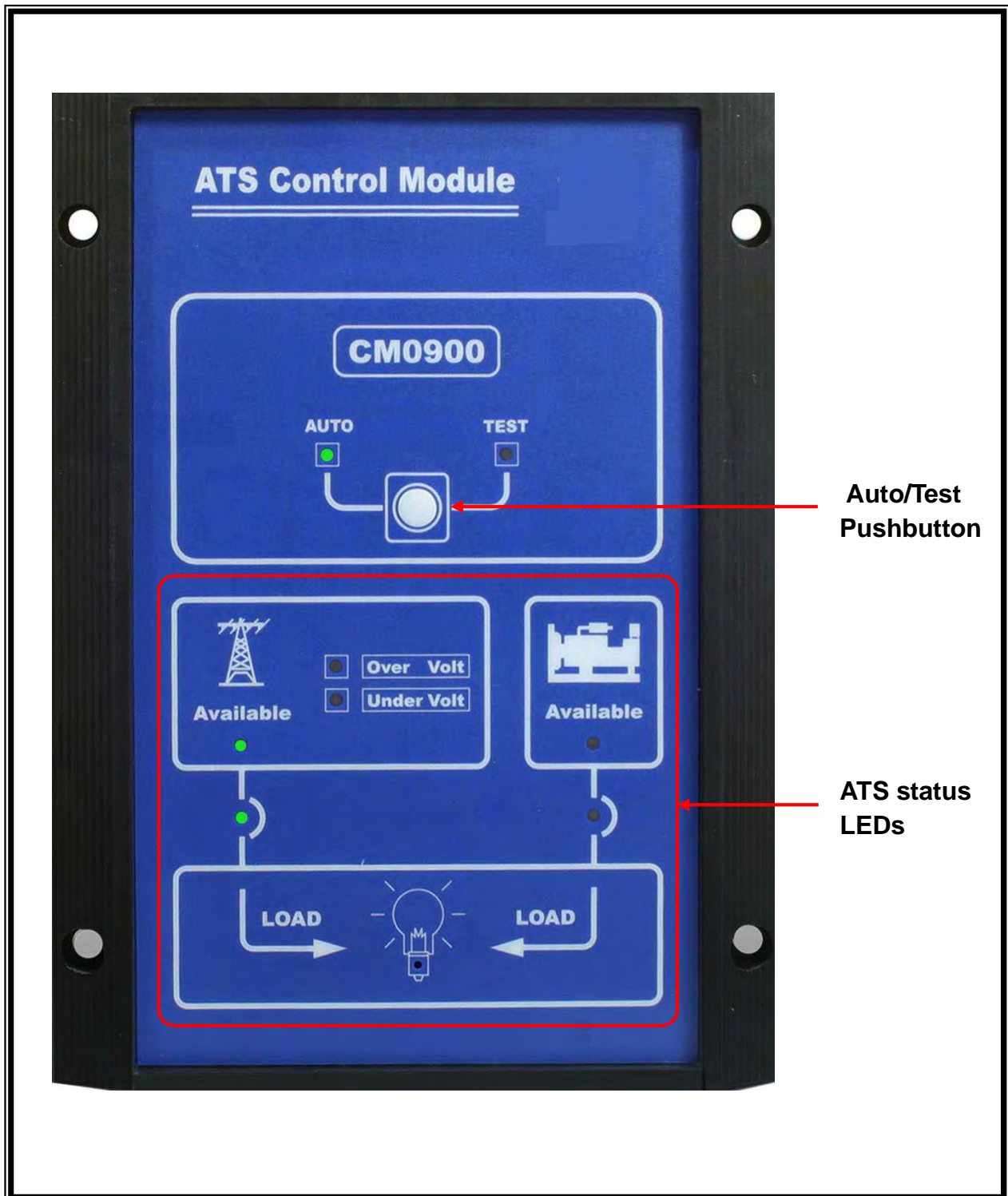

Figure 1

# Rear Layout

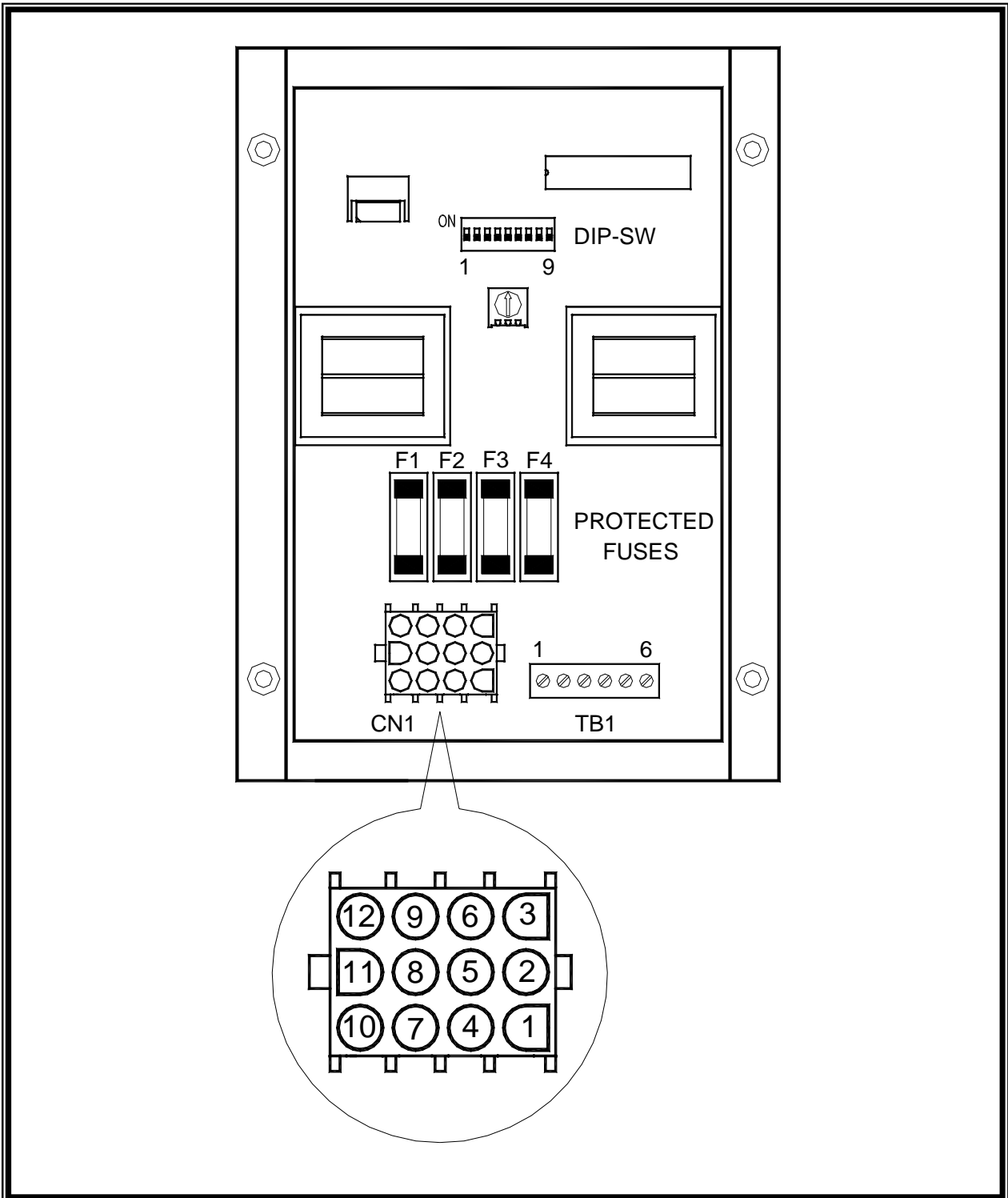

Figure 2

## SECTION 3 : OPERATOR PANEL

### 3.1 General

The operator panel, which is normally accessible from the outside of a panel or door, provides a means for Auto or Test functions and parameter monitoring.

### 3.2 Auto/Test Pushbutton

Pushing the Auto/Test pushbutton when the CM0900 is at TEST position, the CM0900 will run in automatic mode and a LED is provided to indicate the auto position.

Pushing the Auto/Test pushbutton when the CM0900 is at AUTO position, the CM0900 will run in engine test mode and a LED is provided to indicate the test position.

### 3.3 Panel LED Outputs

#### Auto Position ( Green )

Indicates that the CM0900 controller is setting to AUTO function.

#### Test Position ( Green )

Indicates that the CM0900 controller is setting to TEST function.

#### Normal Source Available ( Green )

Indicates that the normal source is available and the voltage is within the 180 ~270VAC.

#### Normal Source Connected ( Green )

Indicates that the transfer switch is connected to the normal source.

#### Standby Source Available ( Green )

Indicates that the standby source is available.

#### Standby Source Connected ( Green )

Indicates that the transfer switch is connected to the standby source.

#### Normal Over Voltage ( Red )

Indicates that the normal source is unavailable and the voltage is over 270VAC.

#### Normal Under Voltage ( Red )

Indicates that the normal source is unavailable and the voltage is below 180VAC.

## SECTION 4 : OPERATION

### 4.1 General

This section specifically describes the operation and functional use of the CM0900 controller.

- **Auto mode**
- **Test mode**

The practical use of and operation within each category will be discussed. In this section it is assumed that prior sections were reviewed and that operator has a basic understanding of the hardware.

### 4.2 Auto Mode

The automatic mode of the CM0900 controller provides for automatic transfer and retransfers from source to source as dictated by the features supplied and their programmed values.

The CM0900 controller intelligence and supervisory circuits which constantly monitor the condition of both normal and standby power sources thus providing the required intelligence for transfer operations.

For example, automatically initiate an transfer of power when power fails or voltage level drops below a preset value. Exactly what the CM0900 controller will initiate in response to a given system condition depends upon the combination of standard and selected optional features.



### 4.3 Test Mode

When the CM0900 is at Auto position, pressed the Auto/Test pushbutton on the front panel. the CM0900 will run in with load engine test mode, that simulates a loss of normal source. The TDES and TDNE programmed time delays will be performed as part of the Test.

When the user terminated the engine test mode by press the Auto/Teat pushbutton, then the controller will return to automatic mode. When normal power is available, the transfer switch automatically

transfers back from standby source to normal source and initiates engine shutdown after a preset engine cooling down time delay.

### 4.4 Programming

There are 9 setting dip-switches on the rear of CM0900 for Switch type, TDEN, TDNE, TDES and TDEC setting.

For detailed information refer to Paragraph 1.4.1.

## SECTION 5 : INSTALLATION INSTRUCTIONS

### 5.1 General

The CM0900 controller has been designed for front panel mounting.

### 5.2 Panel Cut-Out ( All Dimensions in MM. )

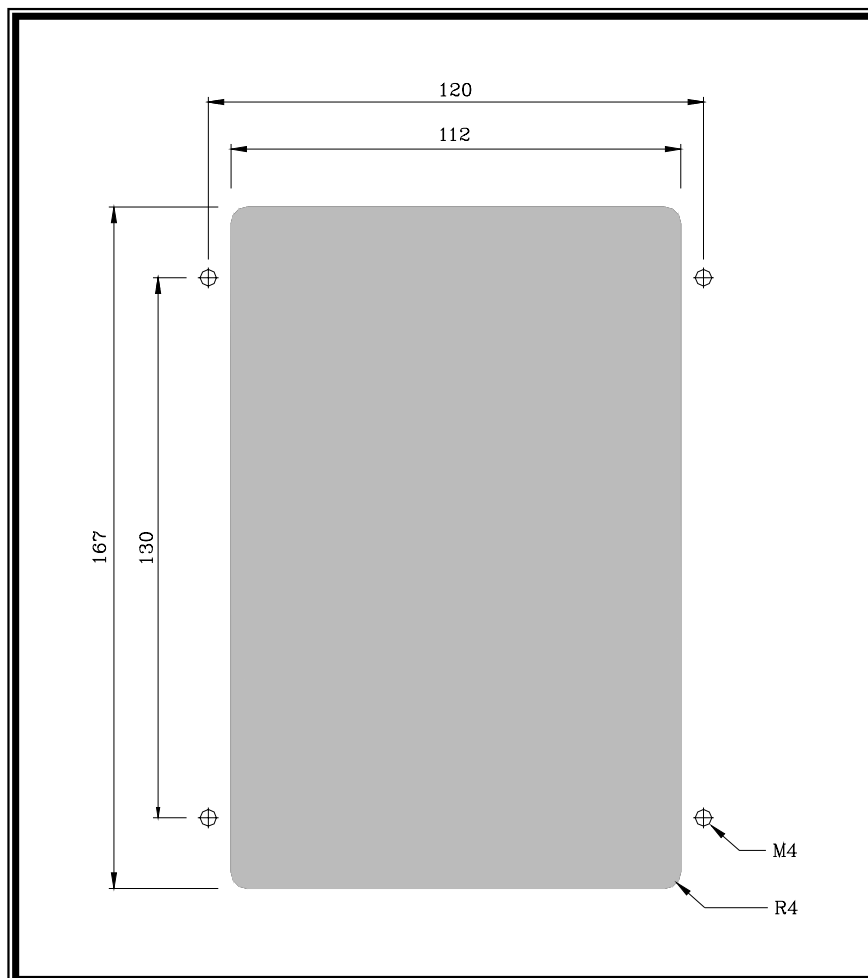

### 5.3 Unit Dimensions ( All Dimensions in MM. )

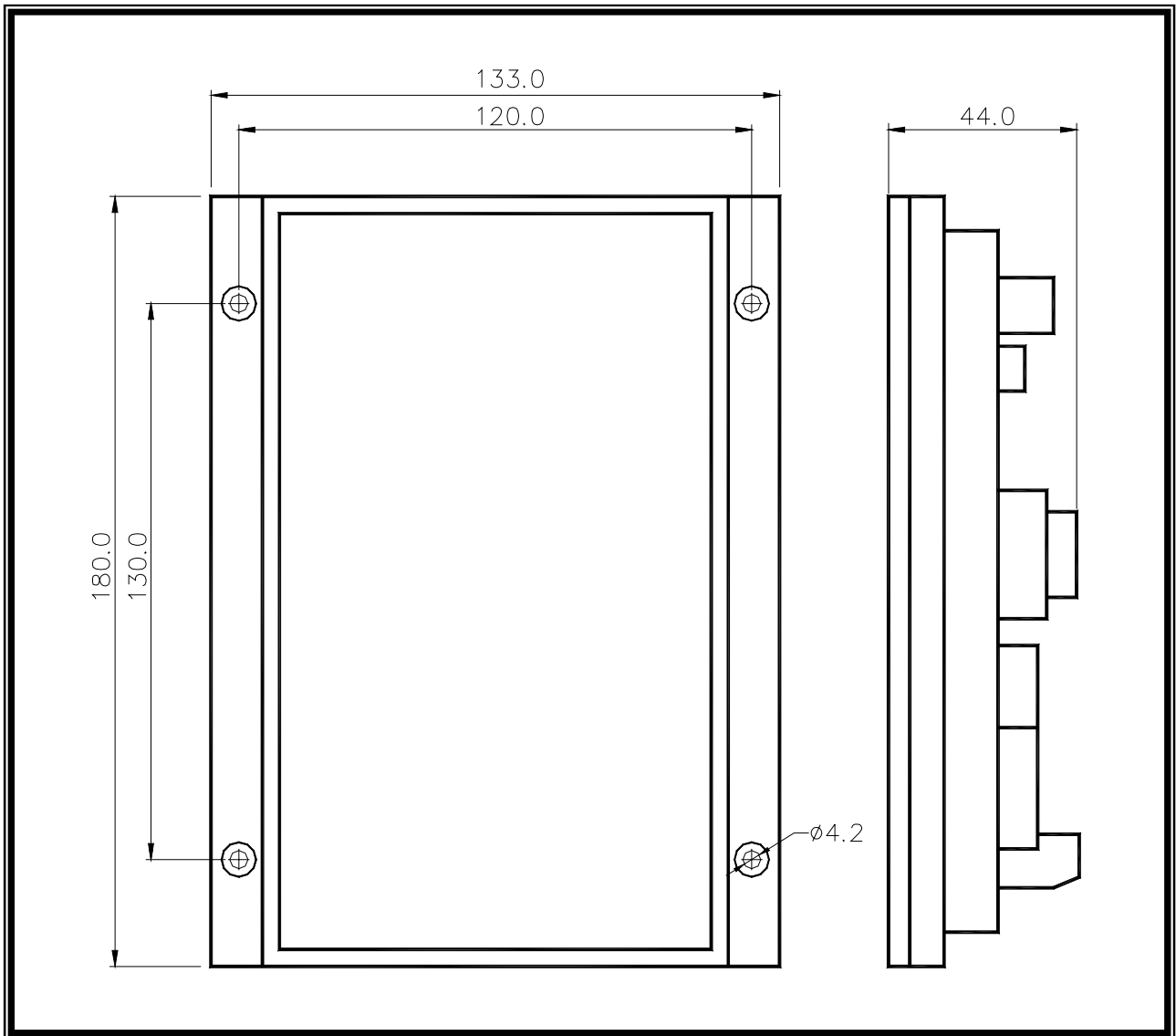

## SECTION 6 : TYPICAL WIRING

### 6.1 General

It is dangerous to feed high voltage to the CM0900 Printed Circuit boards. The CM0900 controller operates with system voltage from 160 VAC to 270 VAC at 50 or 60 Hz.

When the system voltage is different from 1 $\Phi$ 220 VAC, Use ATS-01 programmable ATS controller module.

The CM0900 maximum transfer current is 6 Amps,. When the switch transfer current over 6 Amps, two external power relays is recommended. ( The connecting wire diagram refer to 6.4 section. )

## 6.2 Typical connecting wire diagram

### 6.2.1 MCCB Type Wiring Diagram (Set Dip-sw1 to off position)

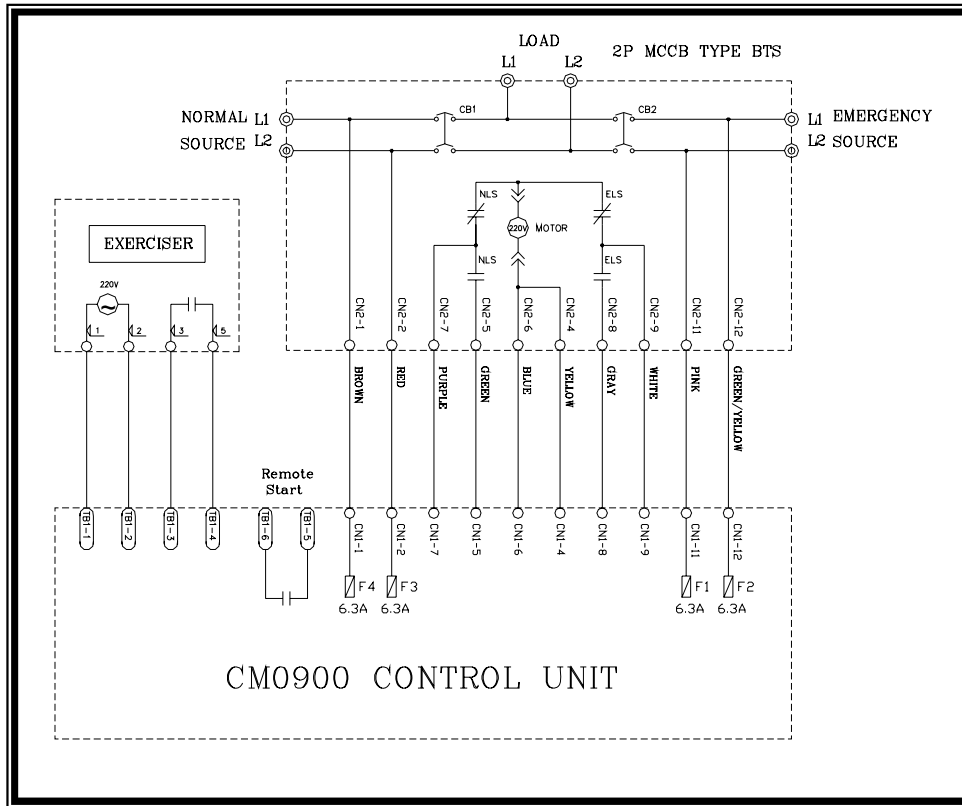

### 6.2.2 One Coil Double Throw Typical Wiring Diagram (Set Dip-sw1 to off position)

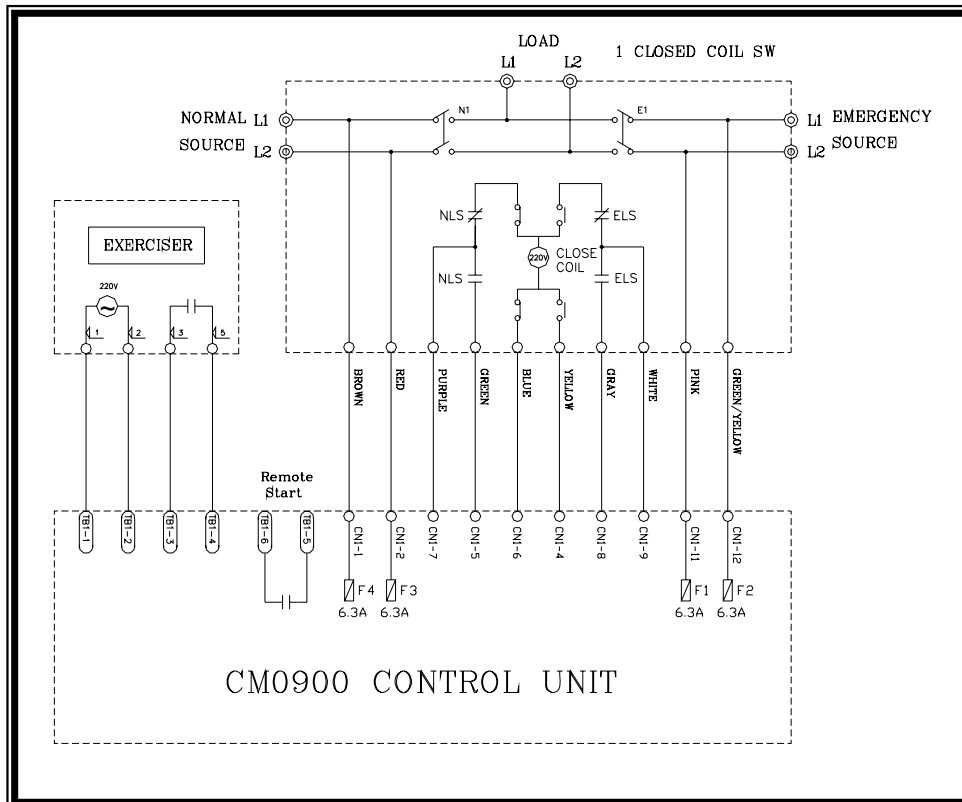

6.2.3 Two Coils Double Throw Type Wiring Diagram (Set Dip-sw1 to off position)

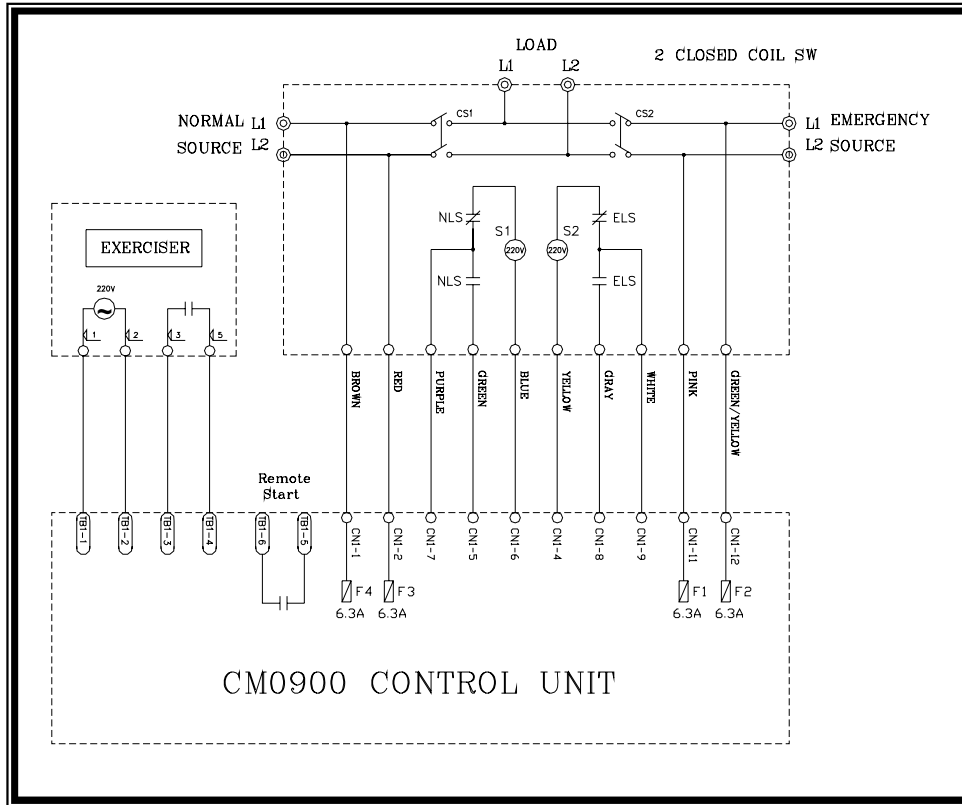

6.2.4 Magnetic Contactor Type Wiring Diagram (Set Dip-sw1 to ON position)

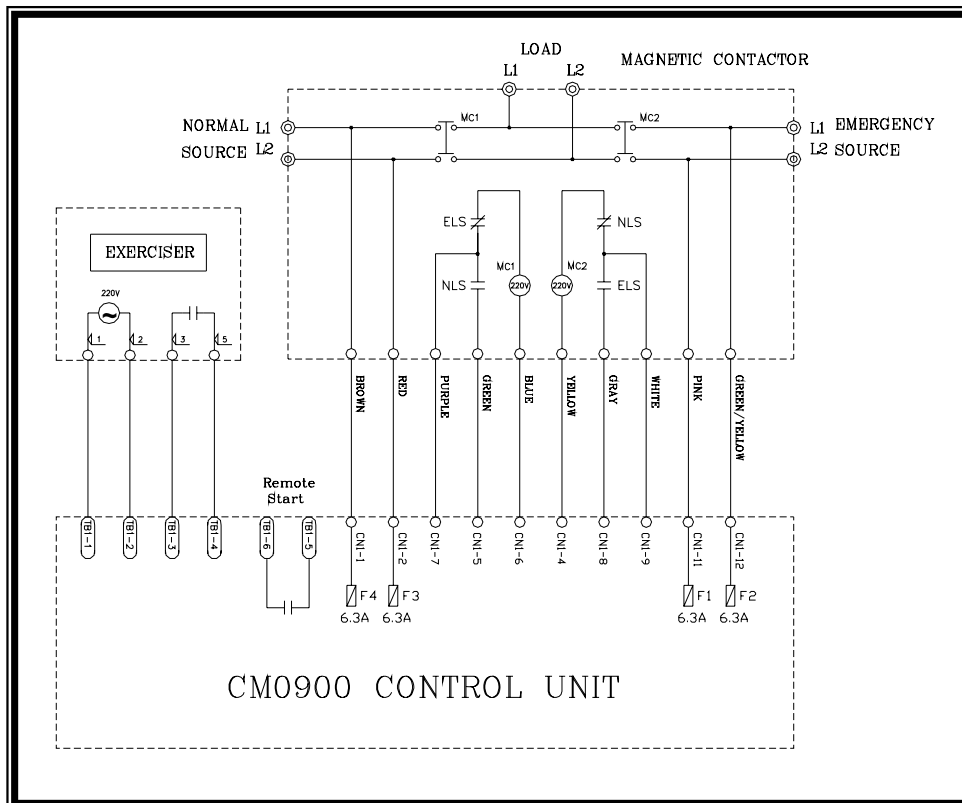

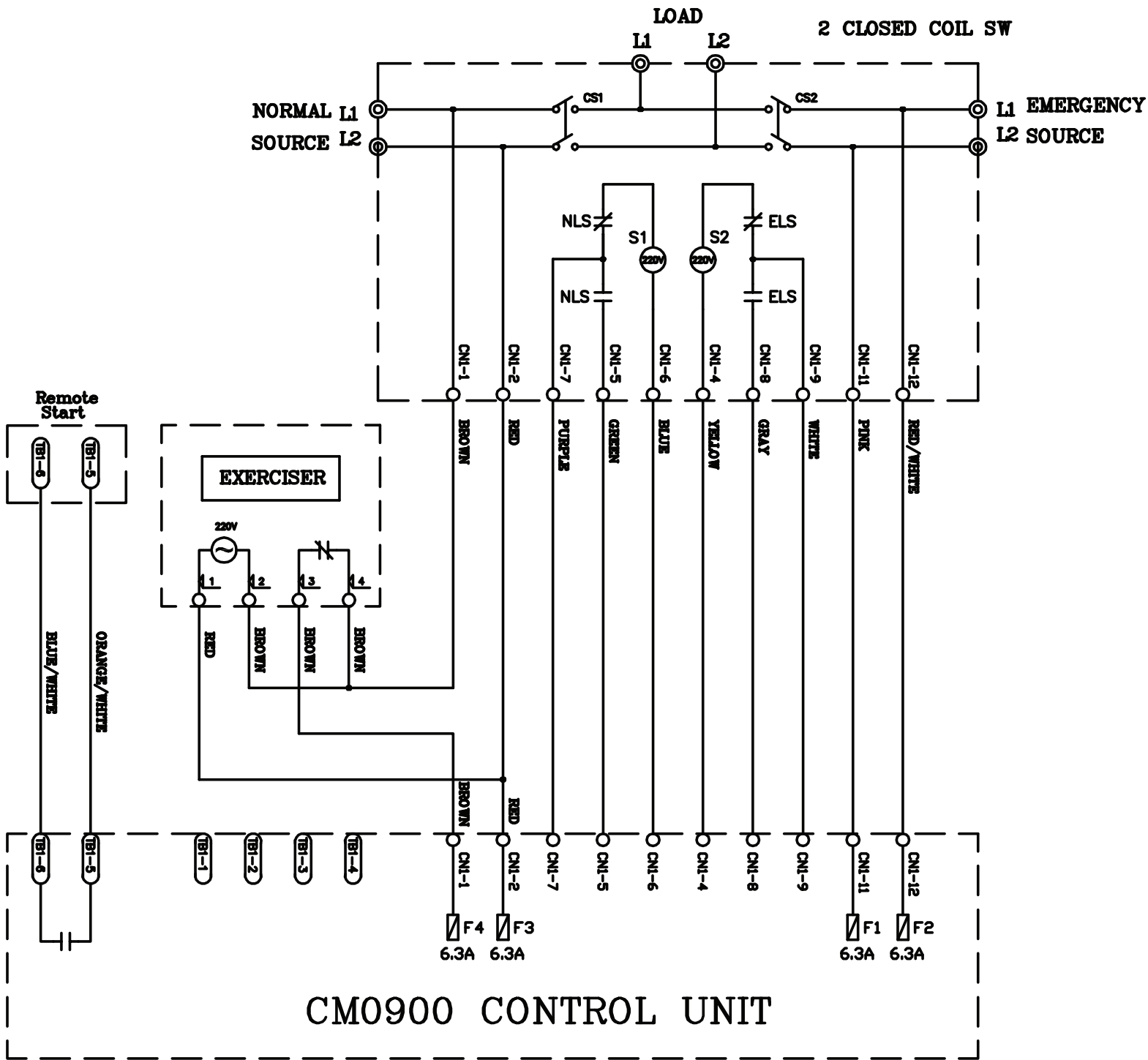

### 6.3 Connecting wire diagram When the switch transfer current over 6 Amps

#### 6.3.1 MCCB Type Wiring Diagram (Set Dip-sw1 to off position)

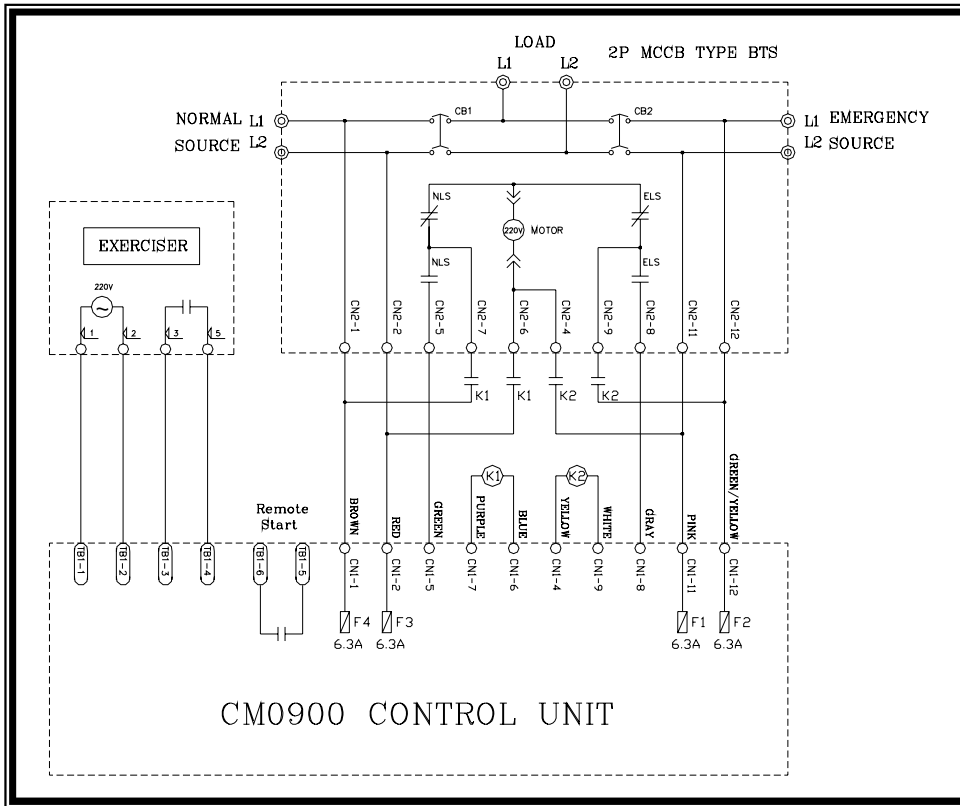

#### 6.3.2 One Coil Double Throw Typical Wiring Diagram (Set Dip-sw1 to off position)

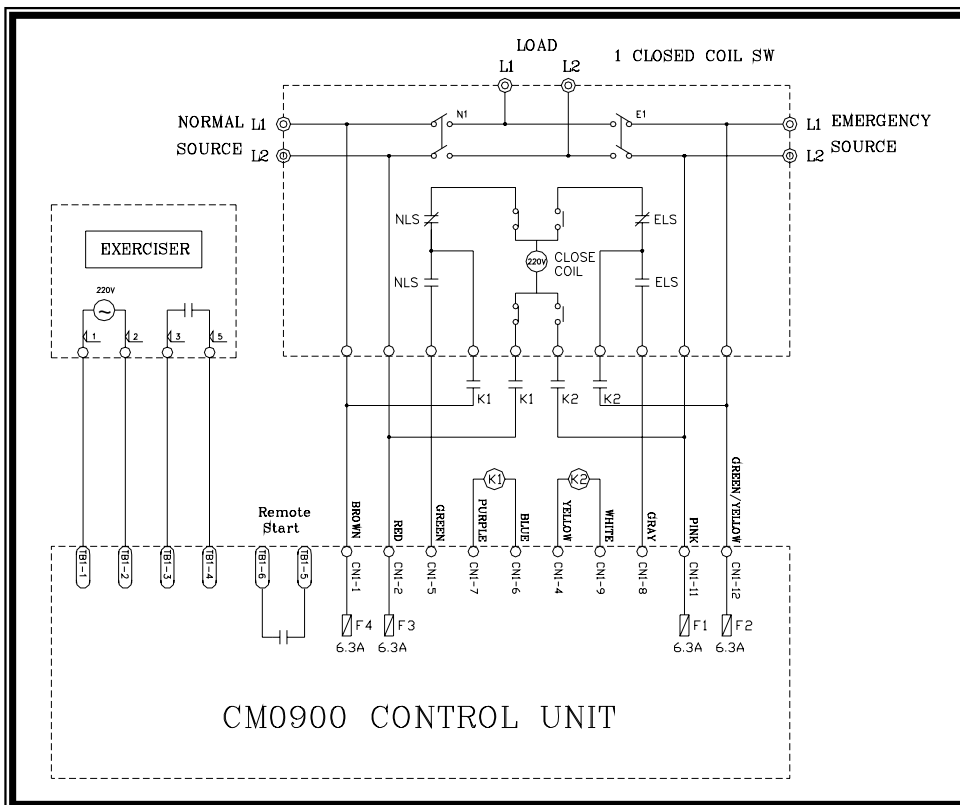

6.3.3 Two Coils Double Throw Type Wiring Diagram (Set Dip-sw1 to off position)

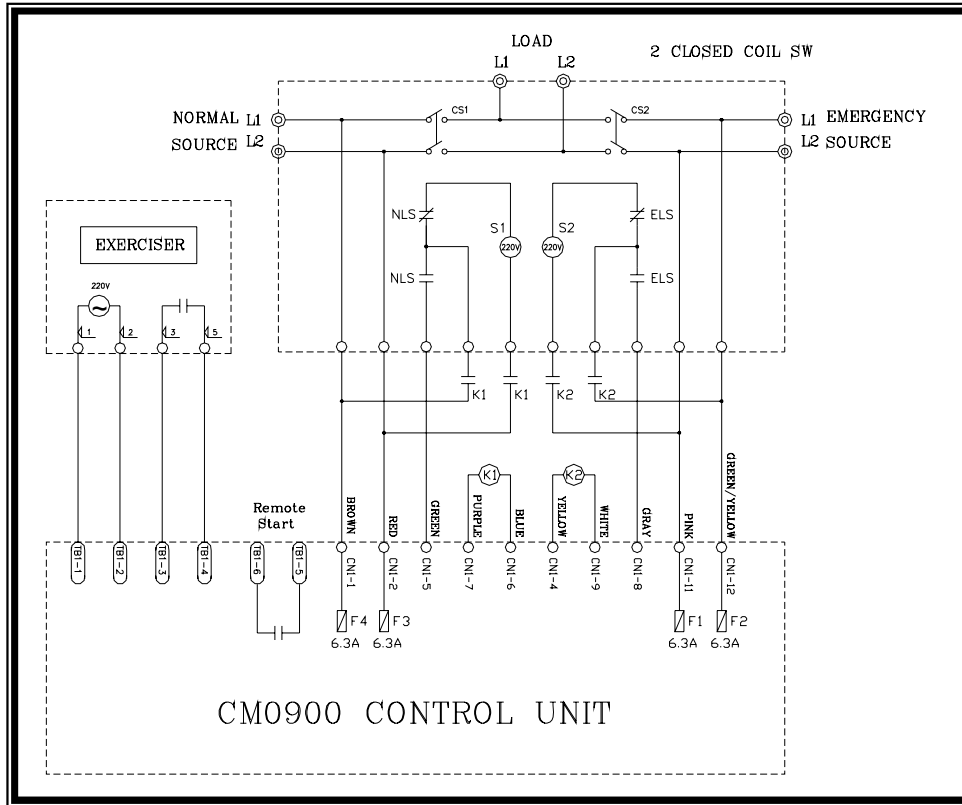

6.3.4 Magnetic Contactor Type Wiring Diagram (Set Dip-sw1 to ON position)

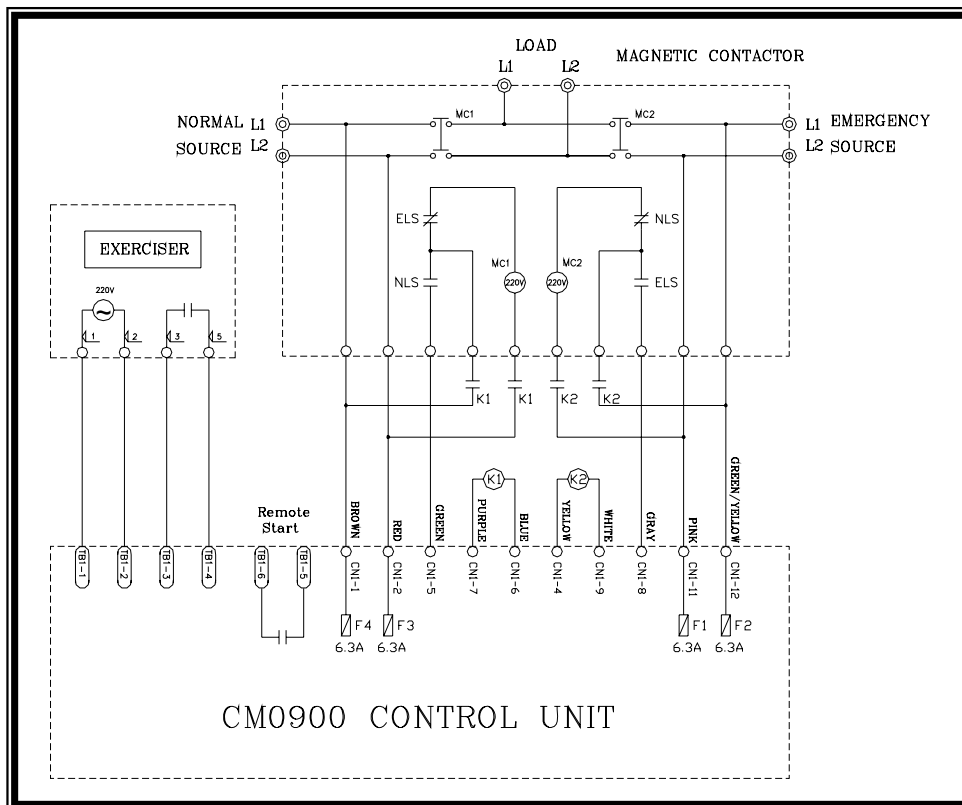

# Programmable Digital Timer Instructions

**IF LIGHT IS ON YOUR GENERATOR IS ALWAYS RUNNING**

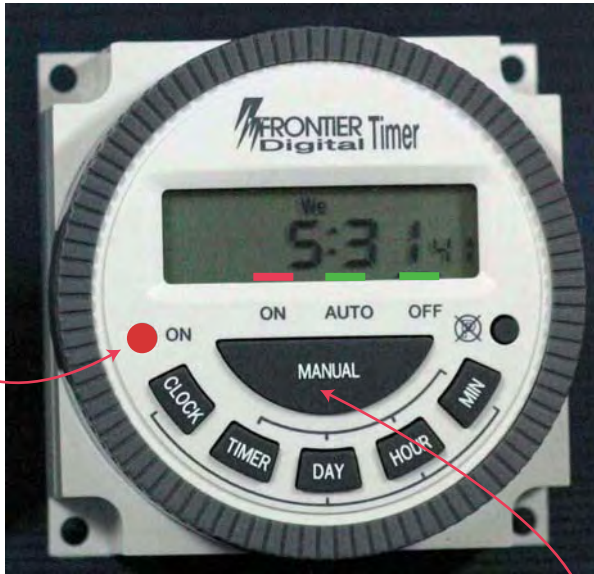

Thank you for buying our product. The following instructions will help you program this timer.

## CAUTION:

1. Installation must be according to wire diagram. See the back of the unit.
2. Press **RESET** button before use.
3. Recharge the battery when no indication appears in the display.

## BUTTON DEFINITION

**Clock:** Current time setting or show current time.

**Timer:** Press this button to enter program mode. There are 8 on / 8 off programs lines.

**Day:** Sets the day of the week.

**Hour:** Sets the hour button. 24 HOUR MILITARY TIME

**Min:** Set the minute button.

**Manual:** ON/AUTO/OFF select mode.

**RESET** Cancel all settings. It is the recessed button next to the circled P with a X through it. Use ballpoint pen to push it.

**ON:** RED LED indicator lamp . LED light on when the internal switch is turned on.

## I: SET CURRENT TIME AND DAY OF WEEK

1. Press CLOCK and DAY buttons together. Pulse the DAY Button to advance to current day.
2. Press CLOCK and HOUR buttons together. Pulse the HOUR button to advance to current Hour.
3. Press CLOCK and MIN buttons together. Pulse the MIN button to advance to current time.
4. After setting the day and time, the seconds will automatically reset.

## II: SET PROGRAMS (TIMES ON AND OFF)

1. Press TIMER button once "1ON" will appear at the left side of display. This is the "1" program that you desire the device to turn on.
2. Press DAY button to select the program period.
3. Press HOUR button to set hour.

4. Press MIN button to set minute.

5. After setting the "1ON" program. then press TIMER button again "1OFF" will appear. this is the "1" program that you desire the device to turn off.

6. Repeat the same procedure until "1OFF" program is set.

7. Your timer gives you up to 8 different ON and 8 different OFF per program period. You can use all 8 settings per period, or as few as required.

## III: REVIEW SET PROGRAMS

1. Pulse TIMER button to advance displayed to each subsequent ON or OFF settings.
2. To make changes follow instructions under " SET PROGRAMS".
3. Push CLOCK button to return to current time display.

## IV: MANUAL OVERRIDE BUTTON

1. Pulse **MANUAL** button to select **ON/AUTO/OFF** mode.
2. **ON** mode turns on the device and it will stay on until manually turned to OFF or AUTO. **OFF** mode turns off the device. and it will stay OFF until manually turned to ON or AUTO.( YOU CAN USE THIS TO TURN ON THE GENERATOR)
3. In **AUTO** mode. It will turn ON or turn OFF according to the programs for which the timer is set.
4. **MANUAL OVERRIDE FEATURE:** Turn device ON if already OFF or OFF if already ON. Timer automatically resumes program on next programmed cycle. (From ON to AUTO mode, it will stay on until the next programmed OFF time armed). (From OFF to AUTO mode, it will stay OFF until next programmed ON time)

## CAUTION

**IF THE INDICATOR LIGHT IS ON. THE GENERATOR IS ON OVERRIDE AND IT IS GOING TO RUN CONTINUOUSLY WITHOUT CONTROL OF THE ATS SWITCH**